

Switch/Relay wiring is Red/Blue/Green, which goes to the CalTerm White/Brown/Yellow wiring.

R3/S3 is Red/White, 12 volt "comon".

R2/S2 is Blue/Brown, "UP", or "go starboard" button.

R1/S1 is Green/Yellow, other button.

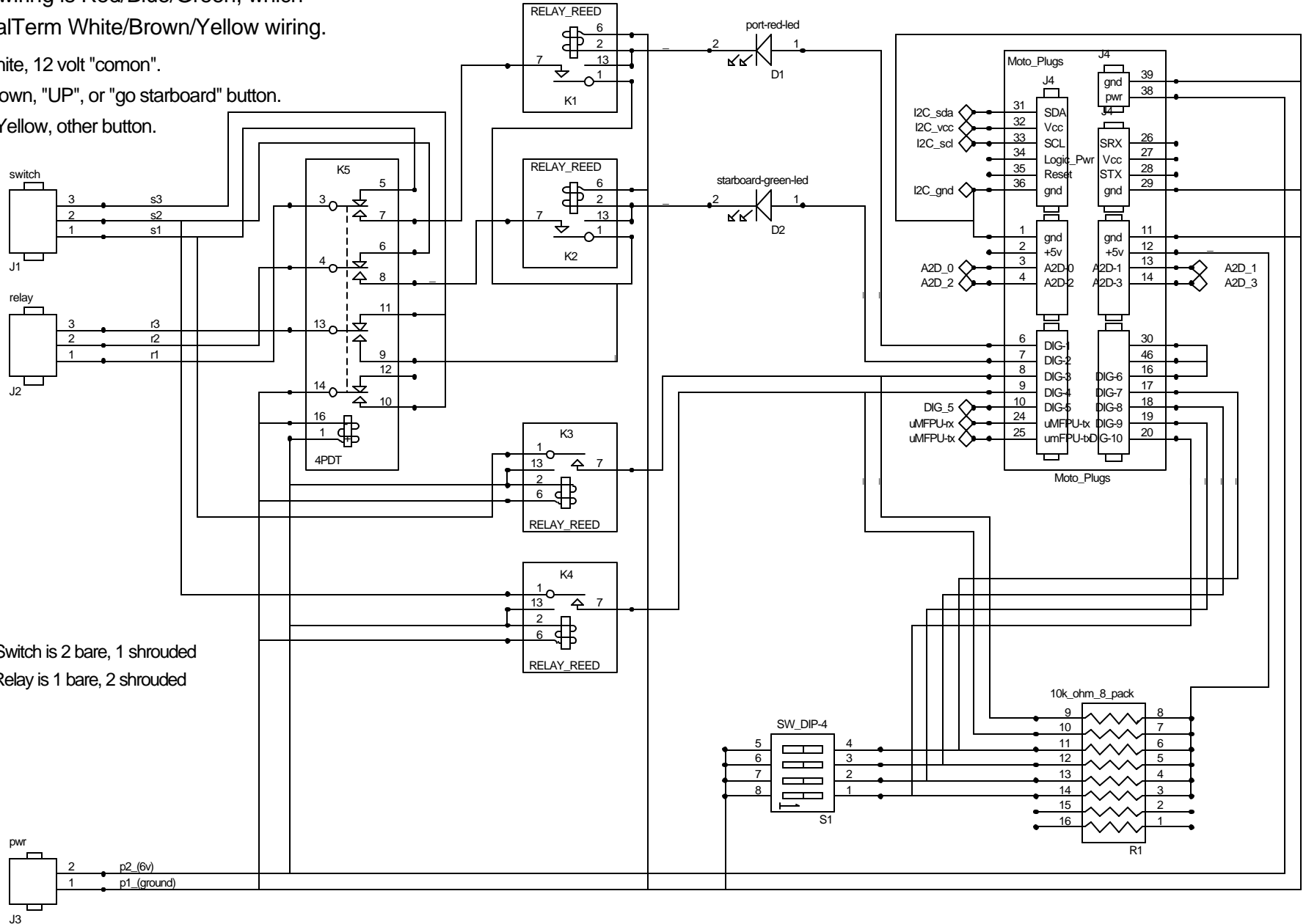

Calterm conn to Switch is 2 bare, 1 shrouded
 Calterm conn to Relay is 1 bare, 2 shrouded

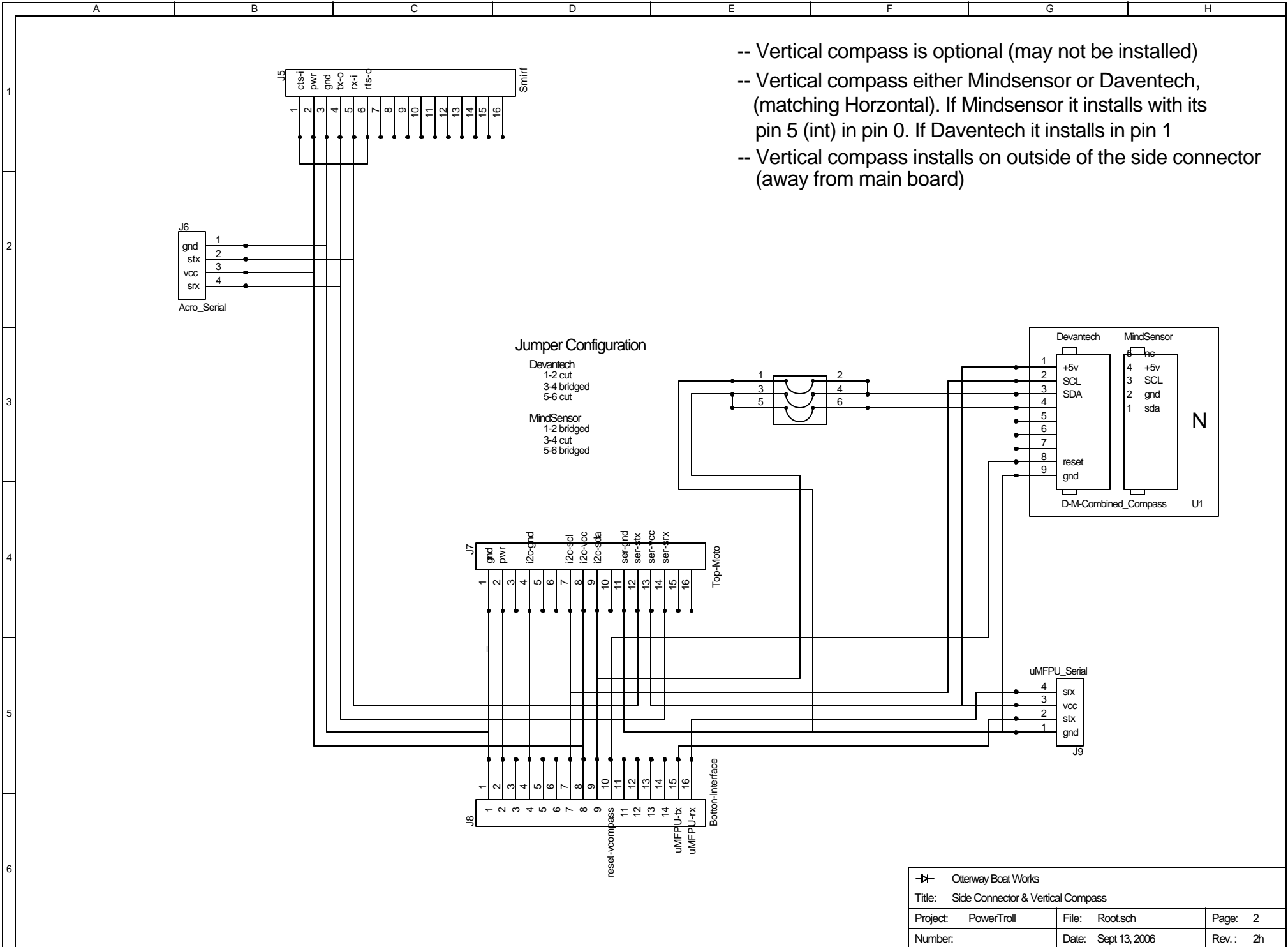

- Vertical compass is optional (may not be installed)
- Vertical compass either Mindsensor or Daventech, (matching Horizontal). If Mindsensor it installs with its pin 5 (int) in pin 0. If Daventech it installs in pin 1
- Vertical compass installs on outside of the side connector (away from main board)

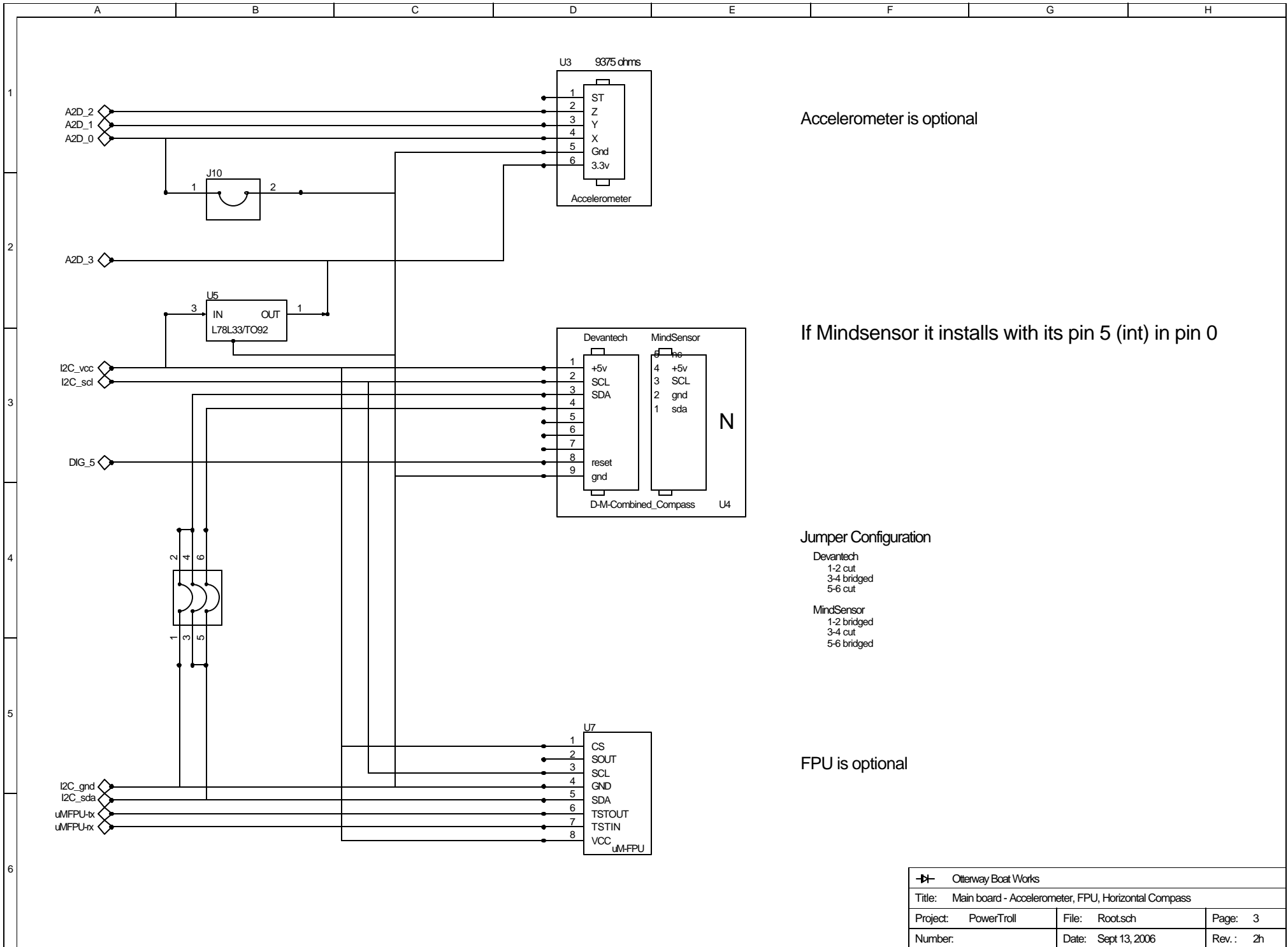

Accelerometer is optional

If Mindsensor it installs with its pin 5 (int) in pin 0

Jumper Configuration

- Devantech
 - 1-2 cut
 - 3-4 bridged
 - 5-6 cut
- MindSensor
 - 1-2 bridged
 - 3-4 cut
 - 5-6 bridged

FPU is optional